

Q1) DSB-SC can be generated using Fig.Q1, if $m(t)$ has a spectrum as shown below.

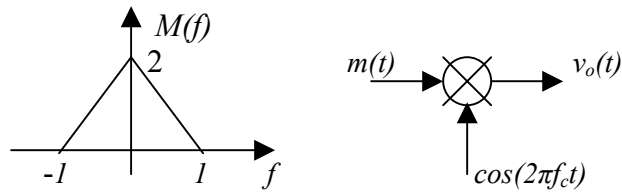

Fig.Q1

- a) Plot the energy spectral density of $m(t)$.
- b) Find the energy of $m(t)$.
- c) Plot the energy spectral density of $v_o(t)$.
- d) Find the energy of $v_o(t)$.

Q2) Fig.Q2 is used to demodulate the single side band SSB.

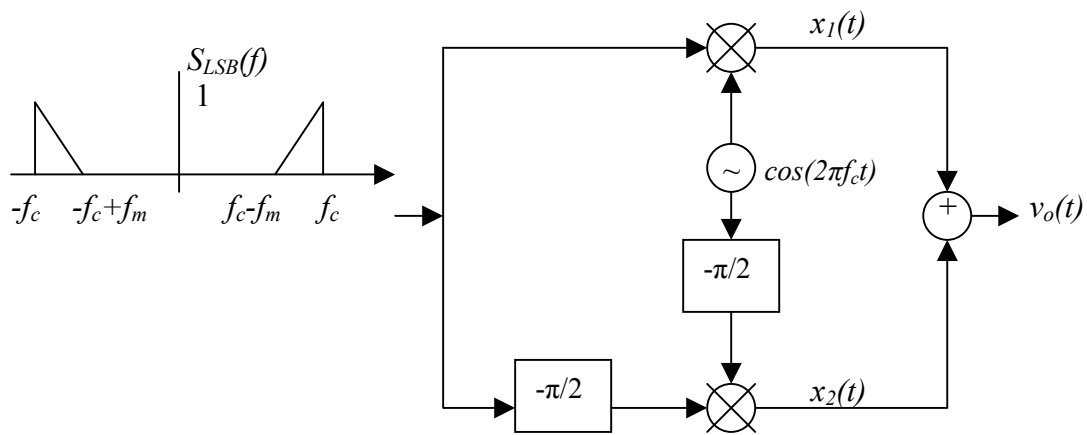

Fig.Q2

Plot the spectrum of $x_1(t)$, $x_2(t)$, and $v_o(t)$.